



Figure S1 BR-TRG-I body cavity thermal perfusion therapy system equipment.

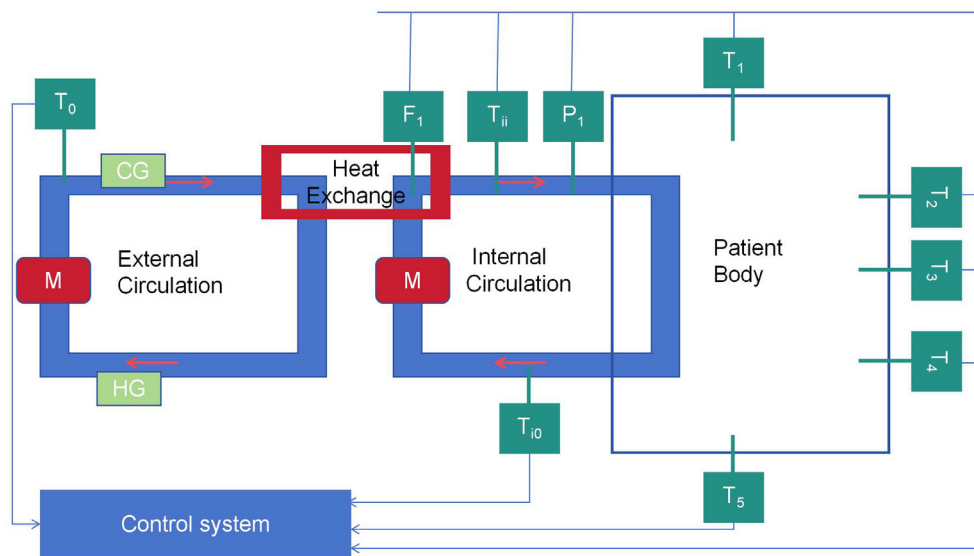

Figure S2 The overall structure of the system. BR-TRG-I body cavity thermal perfusion therapy system structure diagram description: HG, heater with a maximum power of 4 kW and an adjustable heating current; CG, semiconductor refrigerator: the maximum power is 2 kW, and its cooling power is adjustable; T_0 , the temperature of the water in the external circulation heat exchange area, with an accuracy of 0.1 °C; T_{ii} , the temperature of the internal circulation liquid before it enters the human body, with an accuracy of 0.1 °C; T_{i0} , the temperature of the internal circulation liquid after it flows out of the human body, with an accuracy of 0.1 °C; F_1 , the flow rate of the internal circulation liquid, with an accuracy of 10 mL/min, and a resolution of 1 mL/min; P_1 , the pressure of the internal circulation liquid before entering the human body, with an accuracy of 10 mmHg, and a resolution of 1 mmHg; T_0 - T_5 , the temperature of five important parts of the human body; M_1 , the external circulation pump, running at a constant speed of 10 L/min; M_2 , the internal circulation pump; the speed can be controlled up to 600 mL/min; the accuracy is 10 mL/min; the resolution is 1 mL/min.